

Convenience Store with #9 Liquor License



INVESTMENT OVERVIEW

- » A stabilized, income-producing retail asset anchored by a valuable #9
- » Liquor License positioned in one of Mesa's highest-traffic commercial corridors. This is an immediate cash-flow opportunity backed by strong consumer demand.

Investment Type

Equity

Asset Class

Retail

Status

Fully Operational

License

#9 Liquor

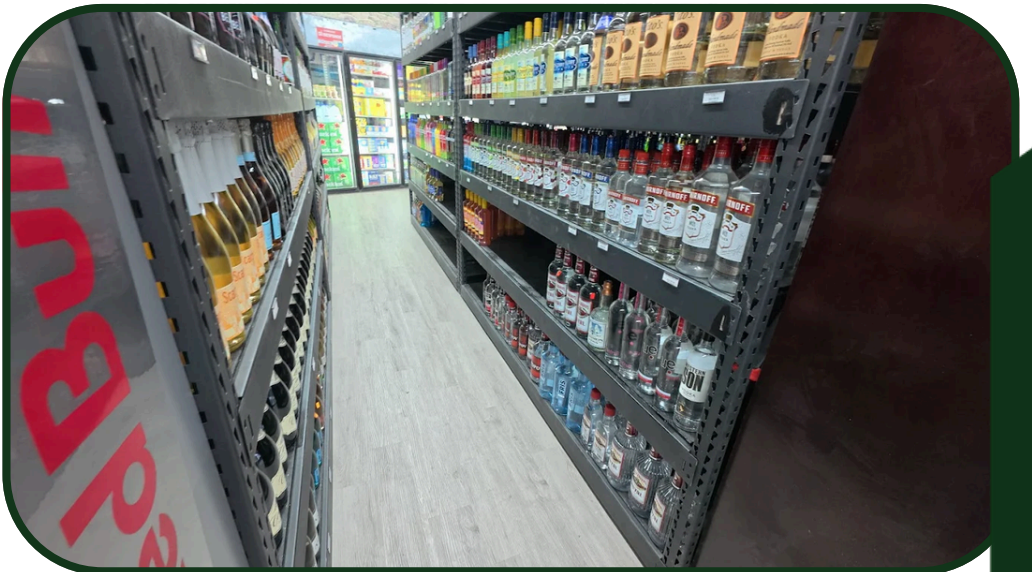

PROJECT DETAILS

INVESTMENT HIGHLIGHTS

»» Five compelling reasons this opportunity stands out for sophisticated investors

1

15% Annual Return

1.25% monthly distributions from day one

2

Fully Operational

No ramp-up period income begins immediately

3

High-Demand Category

Liquor sales drive premium margins and recurring traffic

4

Prime Location

High-visibility retail on a major Mesa corridor

5

Consistent Cash Flow

Predictable monthly income backed by retail fundamentals

INVESTMENT DETAILS

»» Five compelling reasons this opportunity stands out for sophisticated investors

1

Total Acquisition Price

\$2,900,000

2

Equity Raise

\$1,500,000

3

Target Close Date

May 31, 2026

4

Hold Period

2-3 Years

5

Distribution Frequency

Monthly 4 1.25%

LOCATION ADVANTAGE

» Positioned on **McKellips Road** a high-traffic arterial in Mesa the asset benefits from strong residential density, an established commercial ecosystem, and seamless access via major roadways.

High-Traffic Road

Major corridor with consistent daily vehicle and pedestrian flow

Residential Density

Dense surrounding neighborhoods drive recurring customer base

Commercial Ecosystem

Established retail environment with complementary businesses

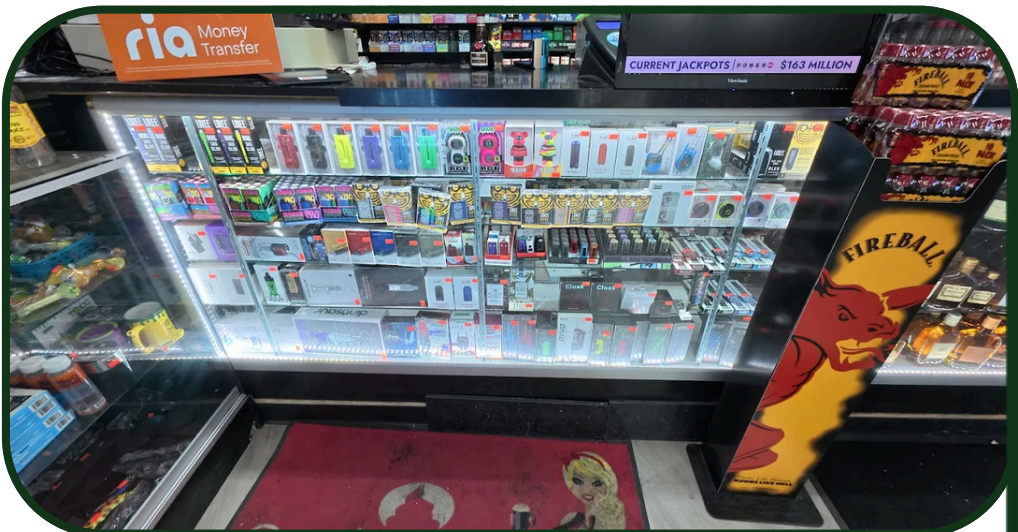

KEY REVENUE DRIVERS

» **Liquor + Convenience = Stable + Scalable Revenue**

» The #9 Liquor License is the crown jewel of this investment – a regulated asset that commands premium margins and creates a defensible competitive moat. Convenience retail adds a reliable, high-frequency revenue floor.



#9 LIQUOR LICENSE

High-Margin Alcohol

● Premium SKUs

Regulatory Moat

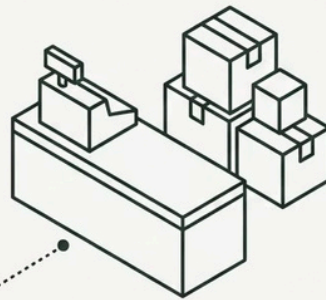

CONVENIENCE RETAIL

Daily Necessities

● Recurring Foot Traffic

Stable Revenue Baseline

① Arizona #9 licenses are limited and highly valued a genuine barrier to entry for competitors.

FINANCIAL PERFORMANCE



15%

Annual Yield

Target return on
invested equity

1.25%

Monthly Distribution

Paid directly to
investors each month

Income Profile

Monthly distributions provide investors with a predictable, passive income stream backed by the recession-resilient demand profile of liquor and convenience retail.

Investment Goal

Stable passive income combined with capital preservation over a 2-3 year hold period, with upside potential at exit.

GROWTH POTENTIAL

» Mesa is one of the fastest - growing cities in the Sun Belt and that tailwind directly benefits this asset.



Population Growth

Mesa's expanding population drives sustained demand for convenience and liquor retail



Rising Commercial Activity

Increased commercial development elevates foot traffic and area desirability



Revenue Expansion Upside

Operational improvements and growing demand create opportunity to increase sales volume

INVESTMENT STRATEGY & EXIT

»» Hold Strategy

Acquire a stabilized, income-producing asset and hold for 2–3 years while collecting monthly distributions. The business requires no major repositioning it generates from day one.

»» Exit Options

Refinance

Refinance after stabilization to return capital

Sale

Sell to income-focused buyers in a strong retail market

Equity Return

Full equity return plus appreciation upside at exit

→ Stabilized income from close

→ Long-term tenant demand

→ Monthly investor distributions

SECURE YOUR POSITION

»» This is a limited opportunity investor slots are filling fast. A high-yield retail investment in a prime Arizona location, backed by a valuable liquor license and strong monthly cash flow.

High-Yield Retail

15% annual return with monthly distributions

Liquor License Moat

Regulated asset with defensible competitive advantage

Prime Arizona Location

Mesa's high-traffic corridor with strong demographics



📌 **Limited Opportunity Investor Slots Filling Fast.** Contact Awesome ROI to secure your position before the raise closes.

Ready to Invest?

Suitable for income-focused investors seeking high short-term yield, comfortable with construction-related risk, and seeking defined timelines.



MANISH PUSHYE

**SPONSOR
& FUND LEAD**



Call

+1 (833)-652-7103



Email

deals@awesomeroi.us

Legal Disclaimer: Targets are illustrative only and not guaranteed. Past performance is not indicative of future results. Securities are offered pursuant to exemptions under Regulation D and are not registered with the SEC. Please review all offering documents carefully prior to investing. **Confidential For Investor Review Only.**